

# Powerhouse Comboni Hospital, Sogakope

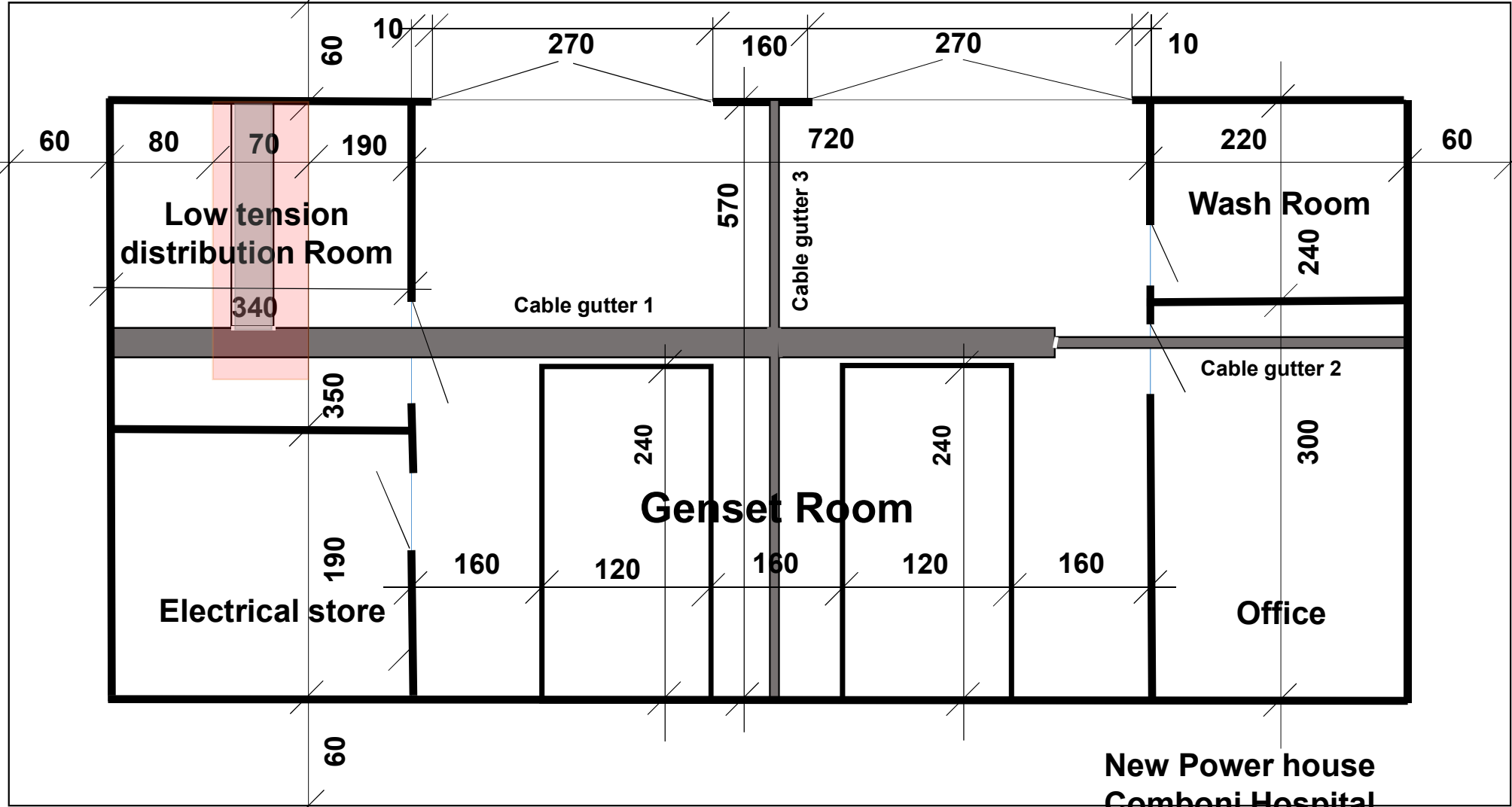

**New Power house  
Comboni Hospital  
Sogakope**

1400

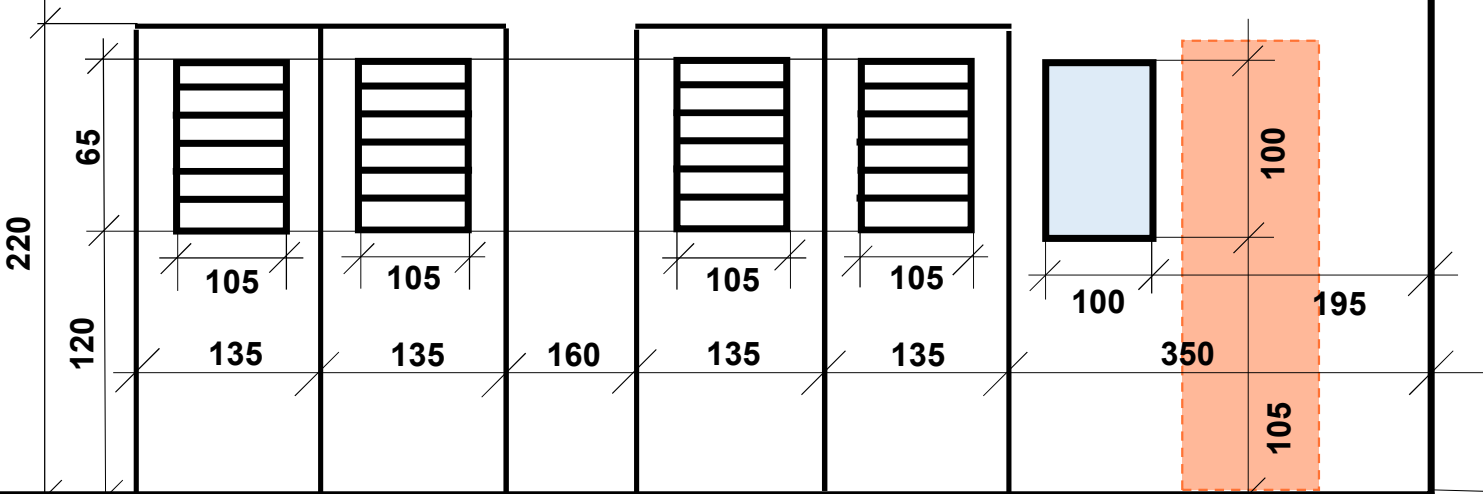
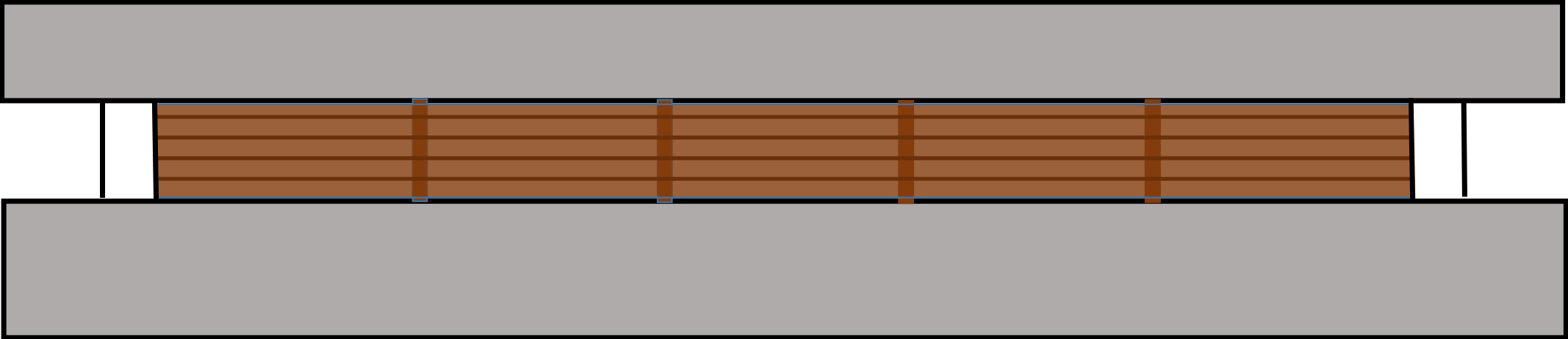

**New Power house  
Gomboni Hospital  
Sogakope**

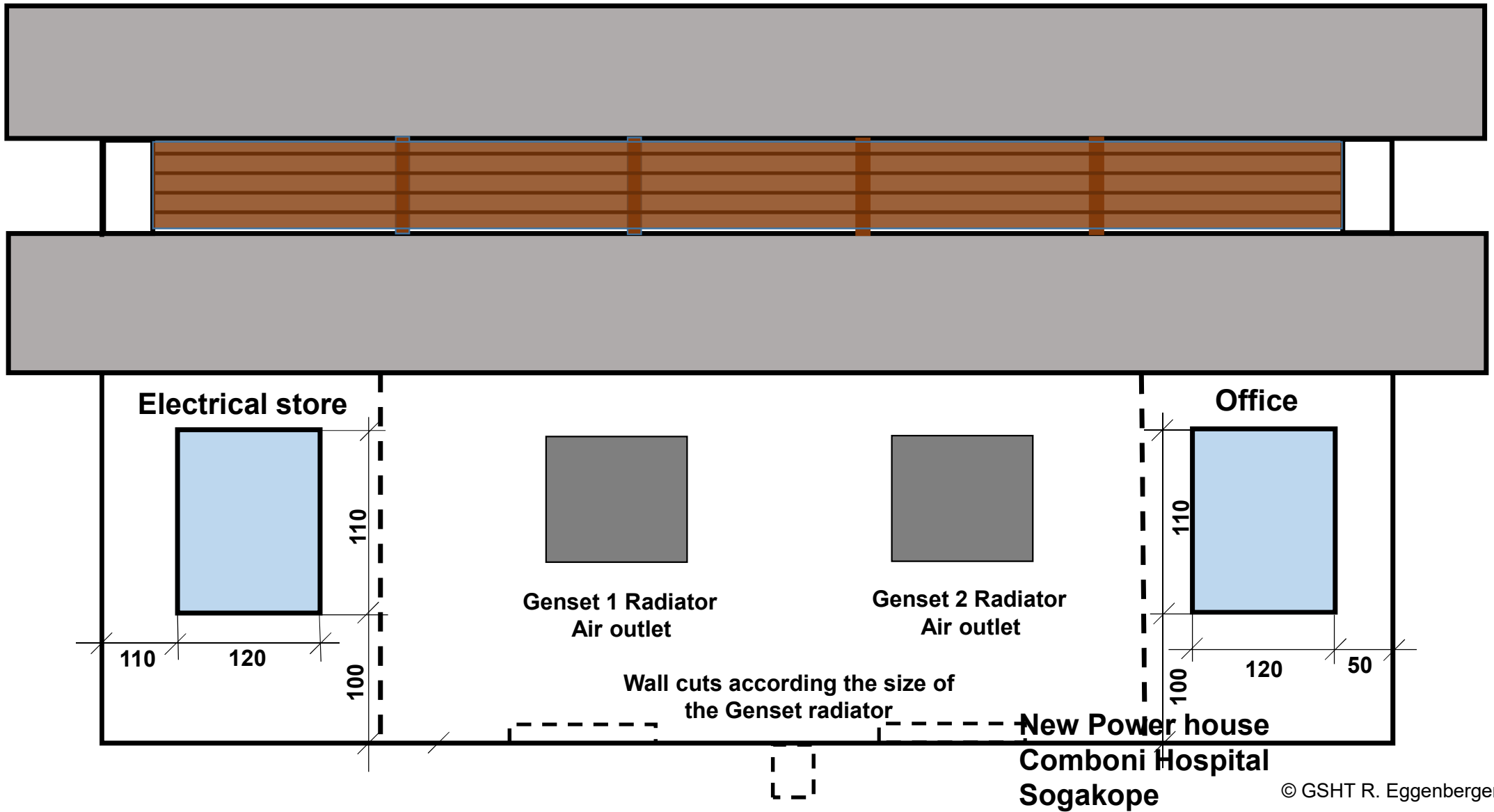

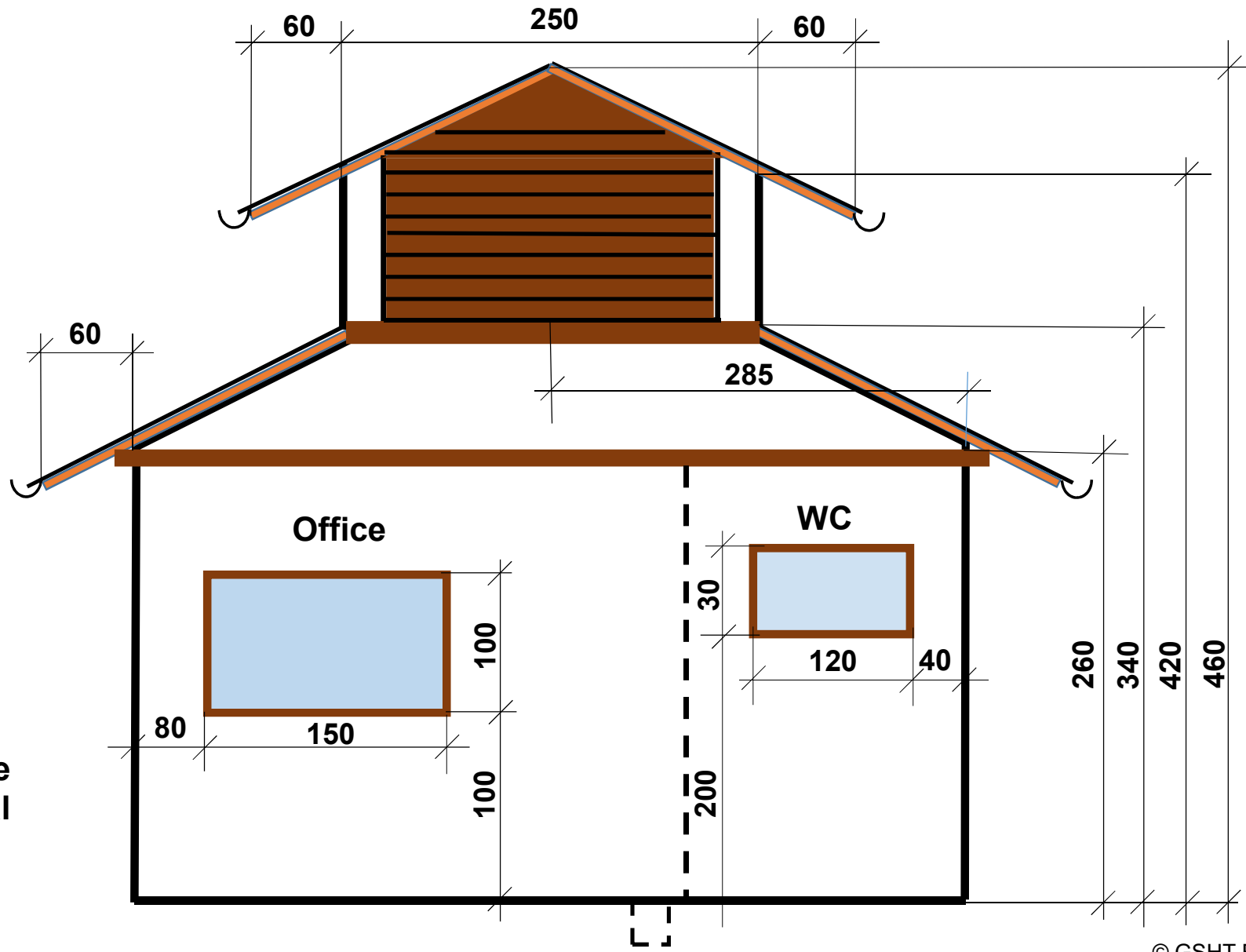

**New Power house  
Comboni Hospital  
Sogakope**

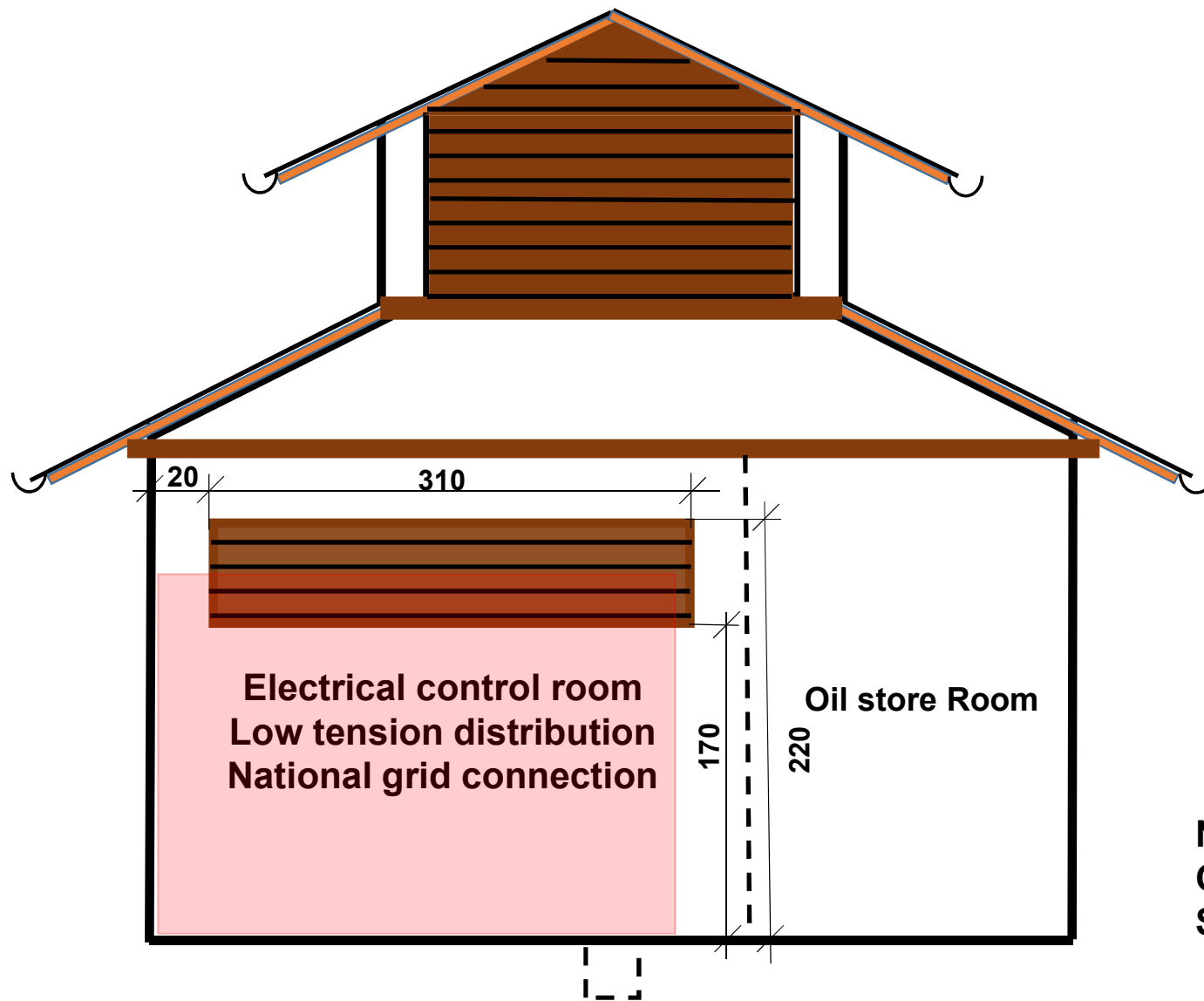

**New Power house**  
**Comboni Hospital**  
**Sogakope**

## Ventilations Louvres Roof, Main entrance doors

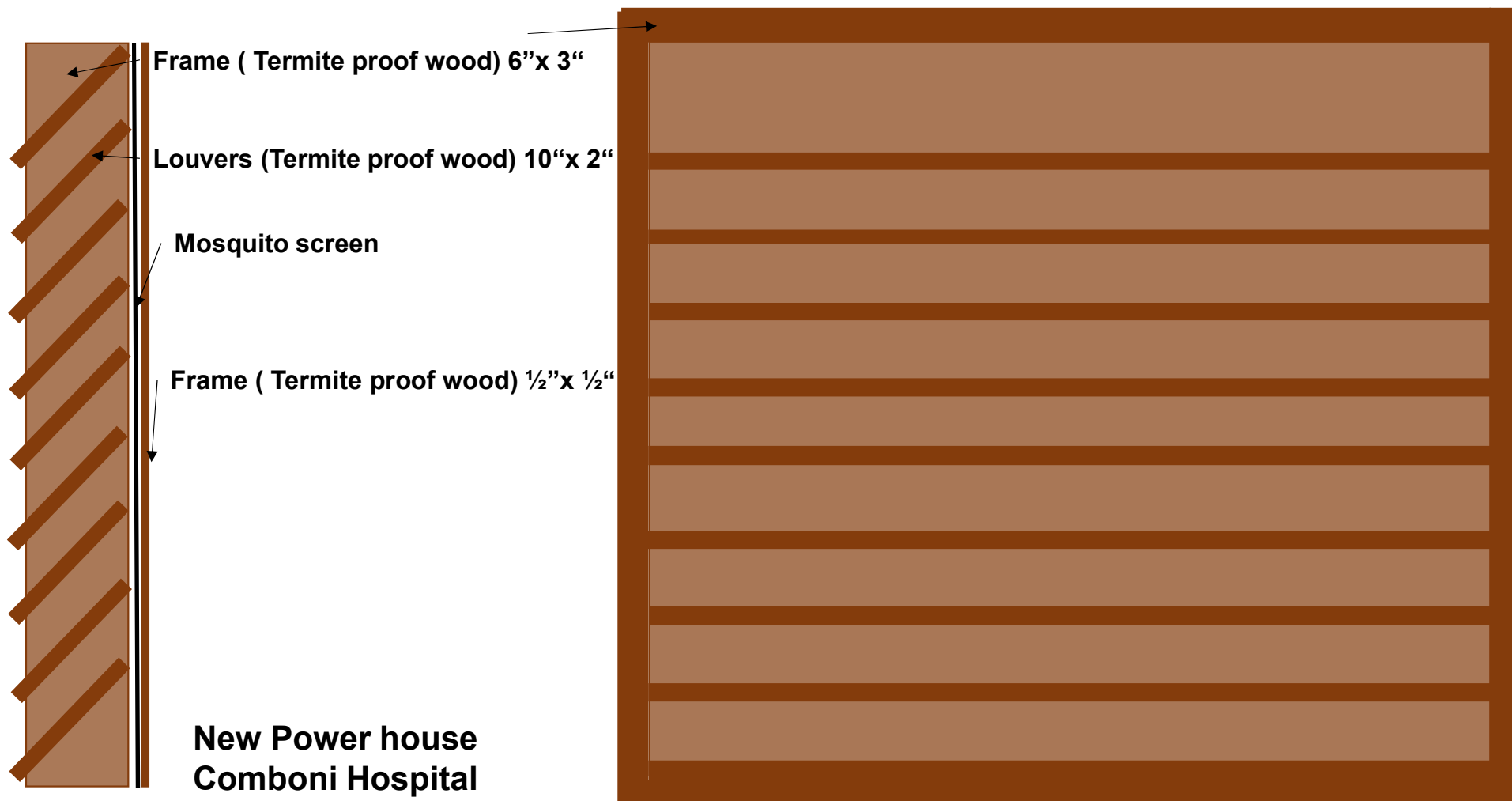

**New Power house  
Comboni Hospital  
Sogakope**

# Cable gutter 1, 2, 3

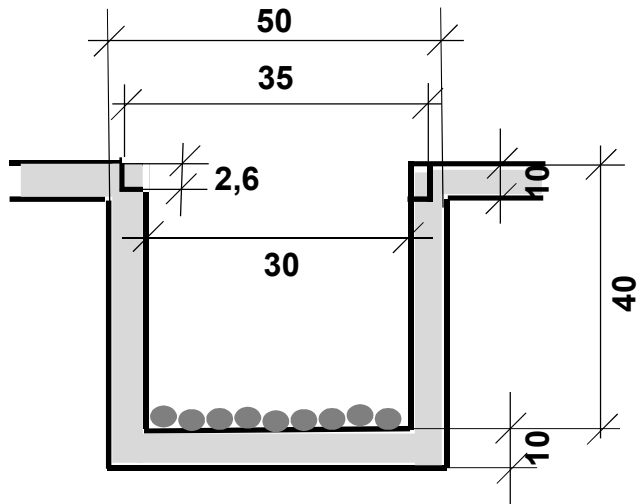

**Cable gutter 1 Generator -  
Low Tension distribution**

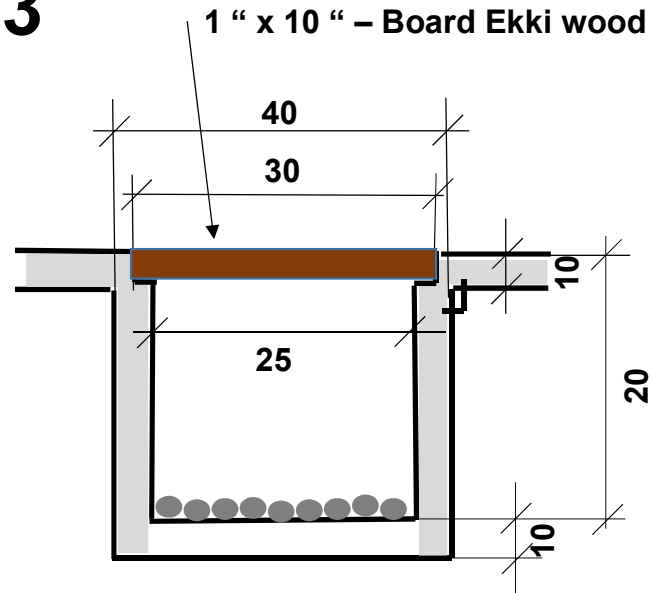

**Cable gutter 2 Generator -  
Grounding- System to Low  
Tension distribution**

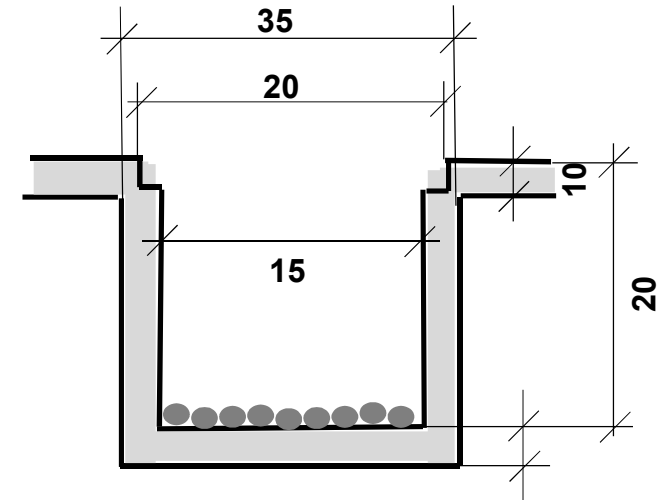

**Cable gutter 2 Grounding- System  
to Low Tension distribution**

**New Power house  
Comboni Hospital  
Sogakope**

All cables gutter must be proper sealed against Lizard, mice, snakes  
All Windows, Ventilation Louvres, Doors must be protected with Mosquitos screen

**Animals and insect cause a high risk of disturbance in electrical switches and circuits, please take note of that !**

# Grounding system Gensets, VRA – ECG- Main -grid

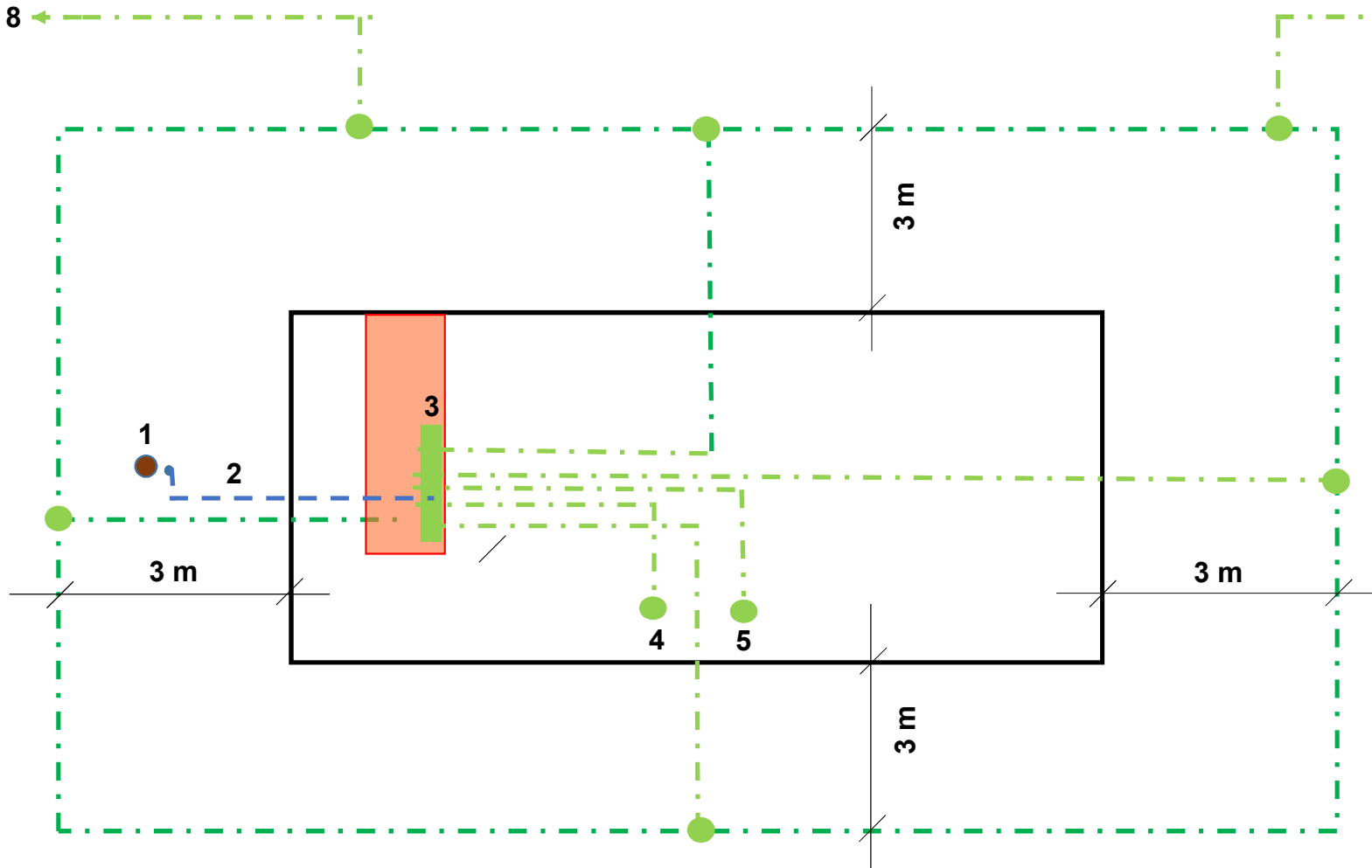

## Legend:

1. ECG – VRA National grid pool
2. Neutral Connection to Ground
3. Central Grounding bar, surge for electrical main feed.
4. Star point Genset 1
- Star point Genset 2
6. Connecting Points to Main Grounding
7. Grounding water system
8. Grounding to Radio tower

Depth of the ditch for the main Grounding system  
 Min. 2 m or 7' (it must be placed in always wet soil)  
 Connection to the Main Grounding point:  
 90 cm deep  $\varnothing$  min. 8 mm or 50 mm<sup>2</sup>  
 Size of the main grounding bar:  
 40mmx5mm in copper.

**New Power house  
 Comboni Hospital  
 Sogakope**



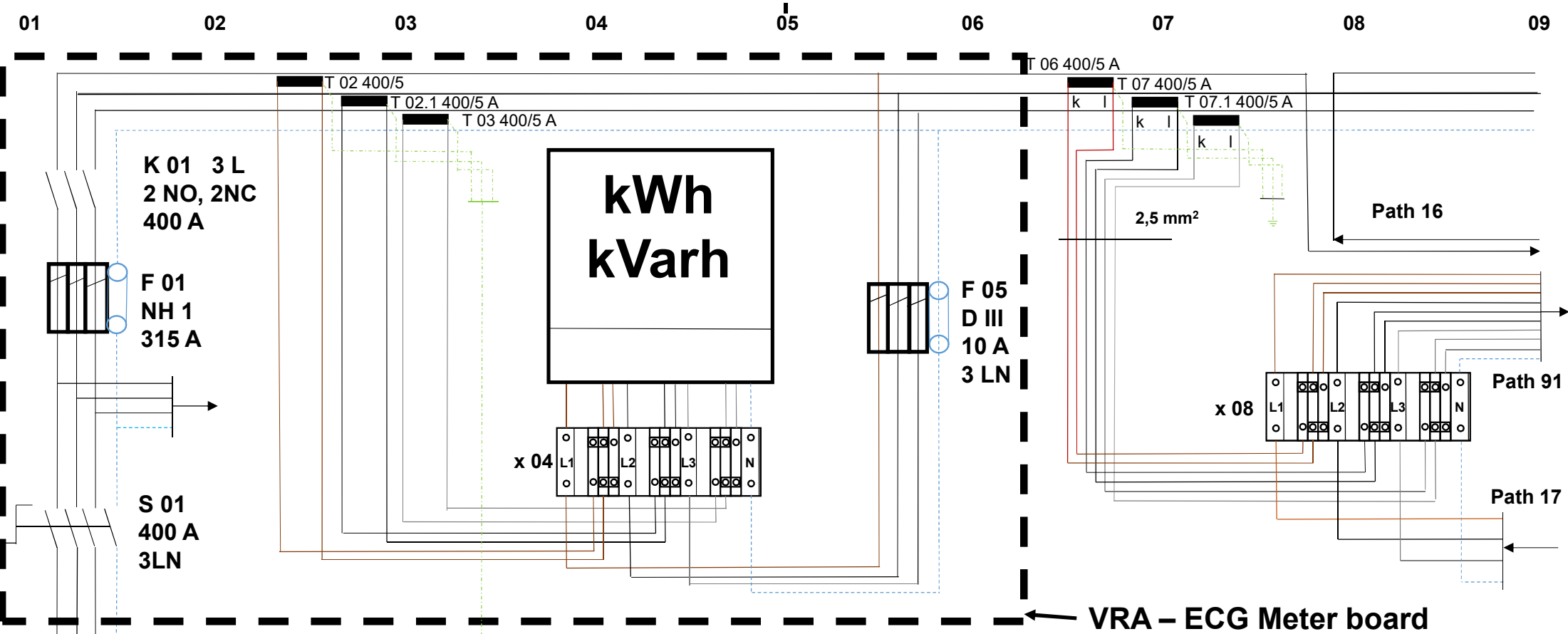

X 01	L1	L2	L3	N	PE	x 02	PE	PE	PE	PE	PE	PE
------	----	----	----	---	----	------	----	----	----	----	----	----

VRA, ECG  
National  
Grid

16.05.2016

Connection South  
Connection North  
Connection West  
Connection East  
Starpoint Genset 1  
Starpoint Genset 2

New Low tension  
distribution  
Comboni Hospital  
Sogakope

00 - 09

© GSHT R. Eggenberger

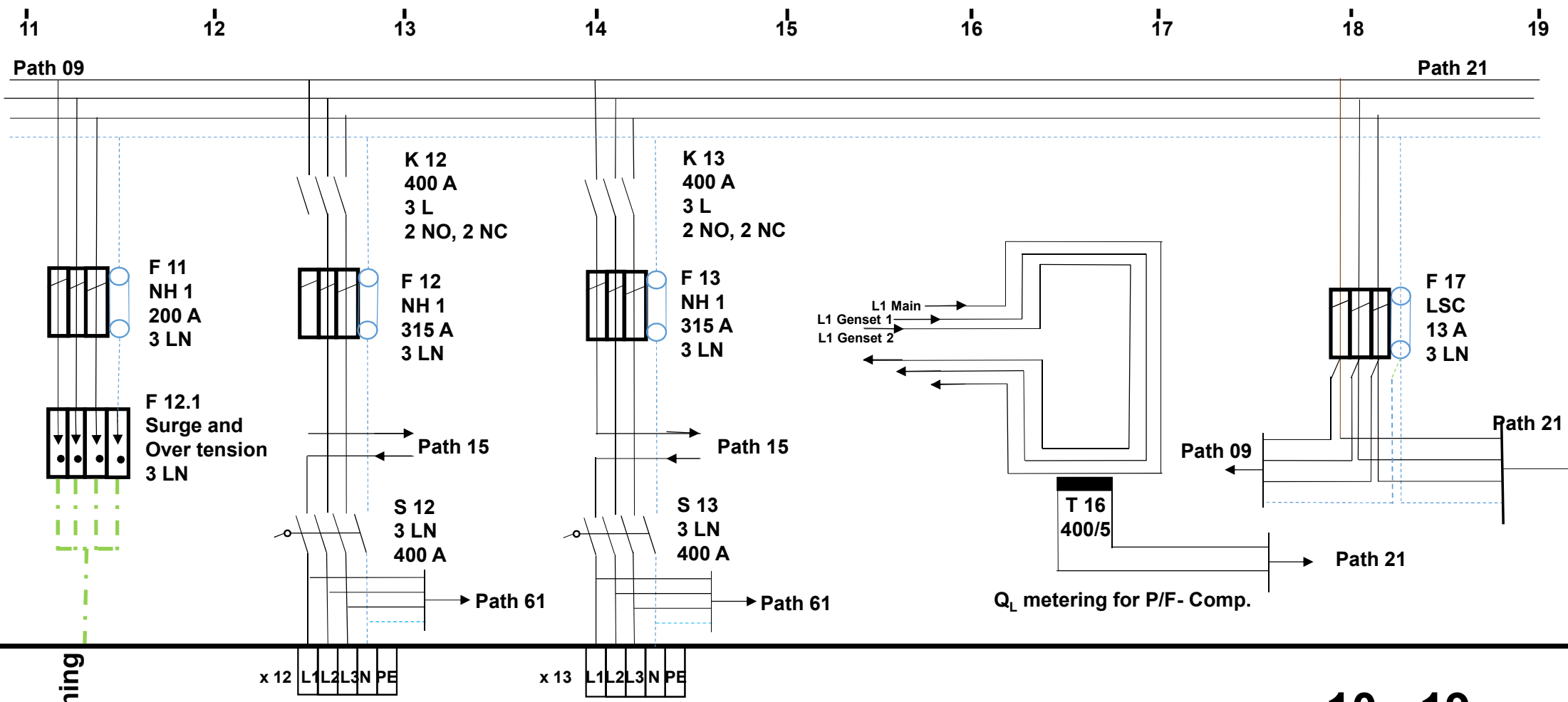

DEHNvenCI  
 Typ 1 1 2  
 Surge & Lightning  
 Protection  
 100 kA  
 10/350µs

x 12 L1 L2 L3 N PE  
 Genset 1  
 200 kVA

x 13 L1 L2 L3 N PE  
 Genset 2  
 200 kVA

New Low tension  
 distribution  
 Comboni Hospital  
 Sogakope

10 - 19  
 Power supply  
 P/F- Comp.  
 Control

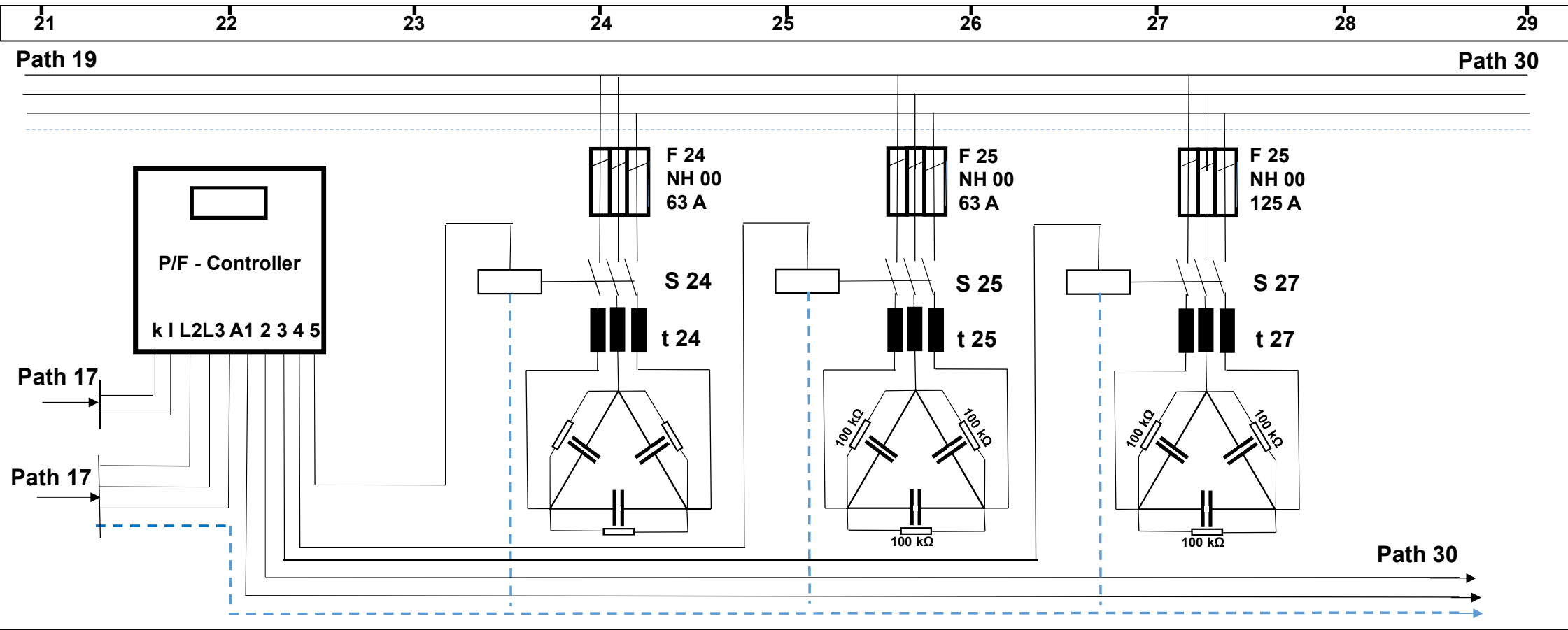

**New Low tension  
distribution  
Comboni Hospital  
Sogakope**

**Step 1  
12,5 kVar**

**Step 2  
12,5 kVar**

**Step 3  
25 kVar**

**20 - 29**

31                      32                      33                      34                      35                      36                      37                      38                      39

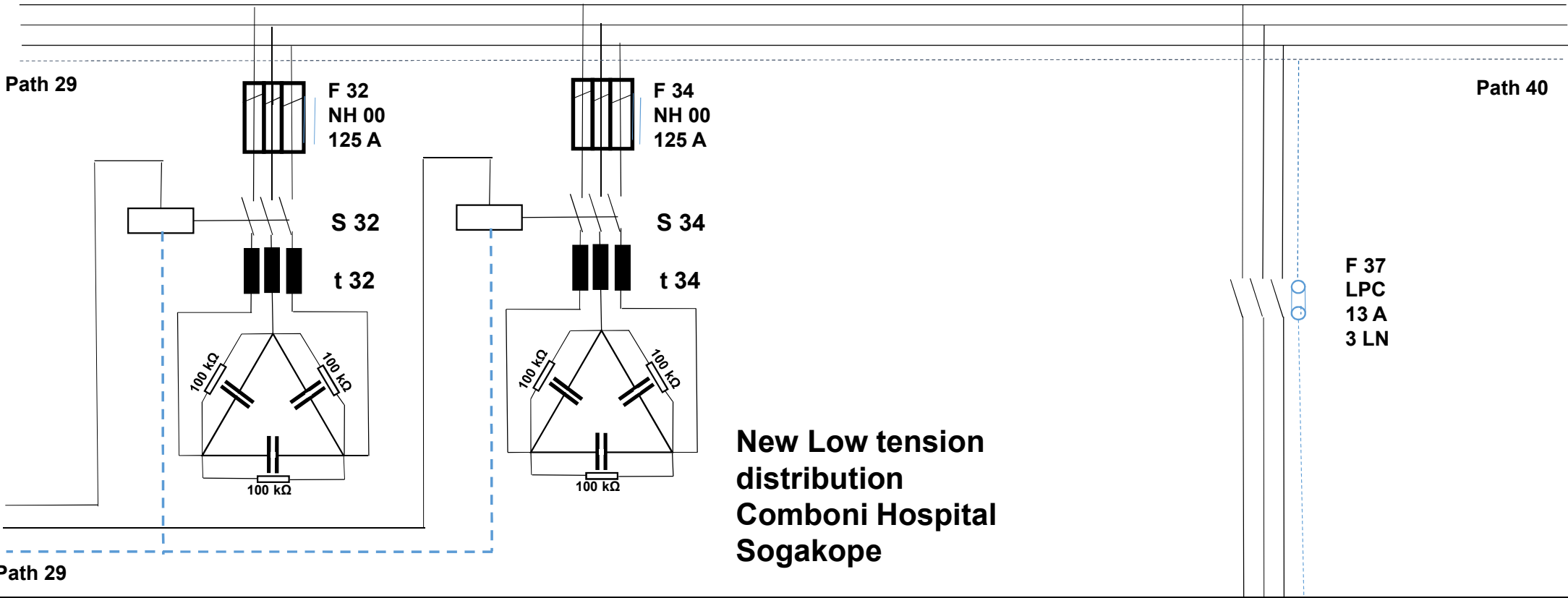

**New Low tension  
distribution  
Comboni Hospital  
Sogakope**

**Step 4  
25 kVar**

**Step 5  
25 kVar**

x 37 L1 L2 L3 N PE

**Batteries charger  
Genset 1  
Genset 2**

**30 - 29**

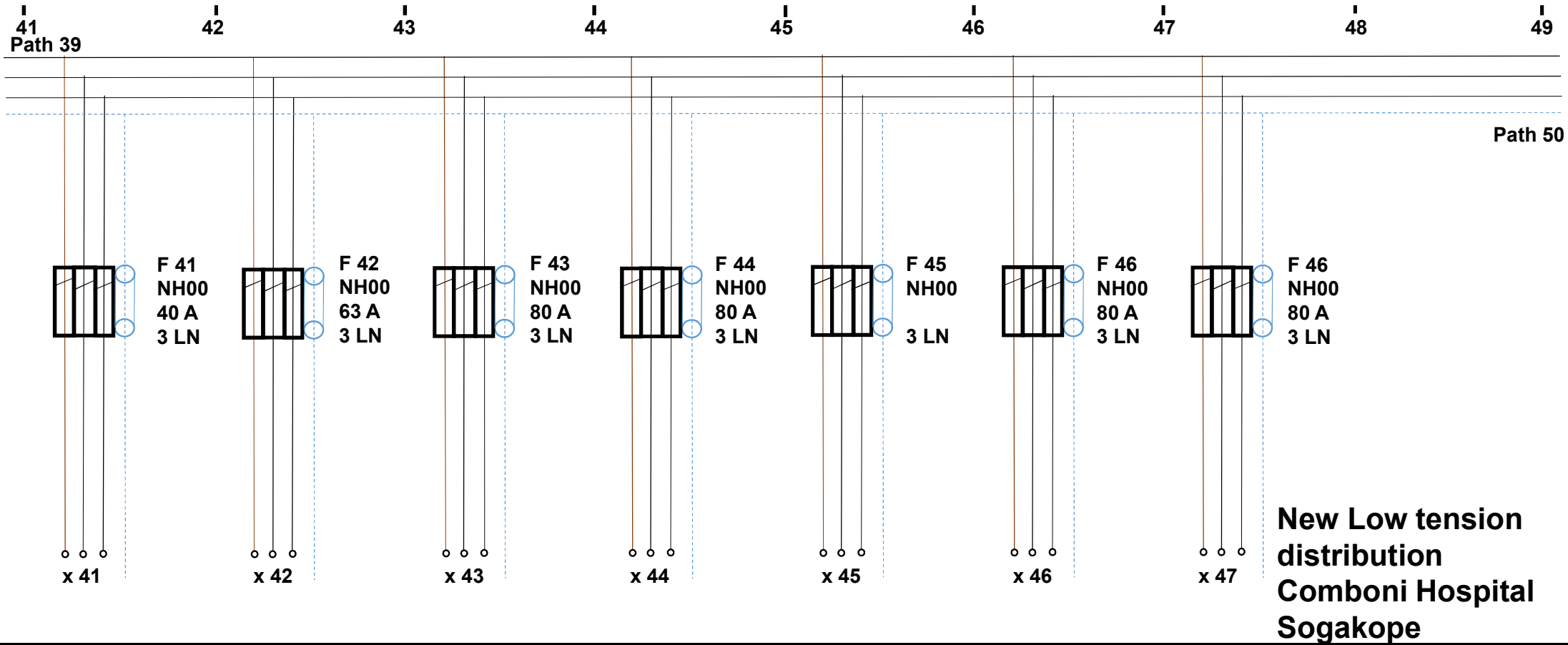

To Water supply  
5 x 10 mm<sup>2</sup>

To dental clinic  
5 x 16 mm<sup>2</sup>

To administration  
5 x 25 mm<sup>2</sup>

To Volunteers  
quarters  
5 x 25 mm<sup>2</sup>

Spare

To laboratory  
5 x 25 mm<sup>2</sup>

To maternity  
5 x 25 mm<sup>2</sup>

**40 - 49**

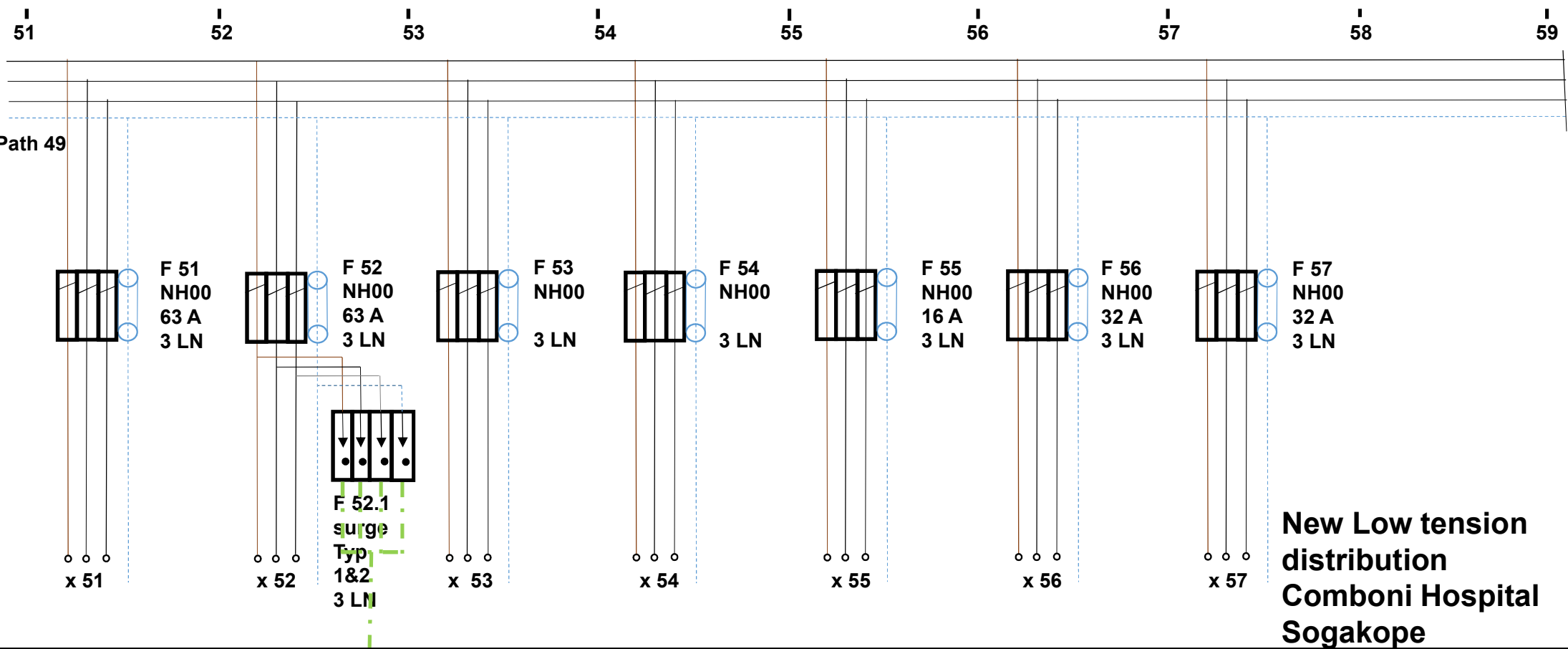

**New Low tension distribution  
Comboni Hospital  
Sogakope**

To kitchen  
5 x 10 mm<sup>2</sup>

To Radio station  
5 x 10 mm<sup>2</sup>

Spare

Spare

Wall socket  
CEE 16

Wall socket  
CEE 32

UPS Theatre  
CEE 32

**50 - 59**

61

62

63

64

65

66

67

68

69

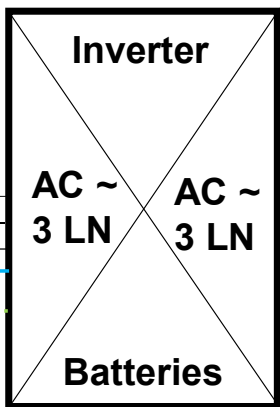

UPS 20 kVA

x 54

F 54  
NH00  
40 A  
3 LN

F 56  
LPC  
13 A  
3 LN

F 57  
LPC  
13 A  
3 LN

Path 61

x 66

Theatre  
5 x 25 mm<sup>2</sup>

Light, Sockets  
Powerhouse

60 - 69

New Low tension  
distribution  
Comboni Hospital  
Sogakope

71 72 73 74 75 76 77 78 79

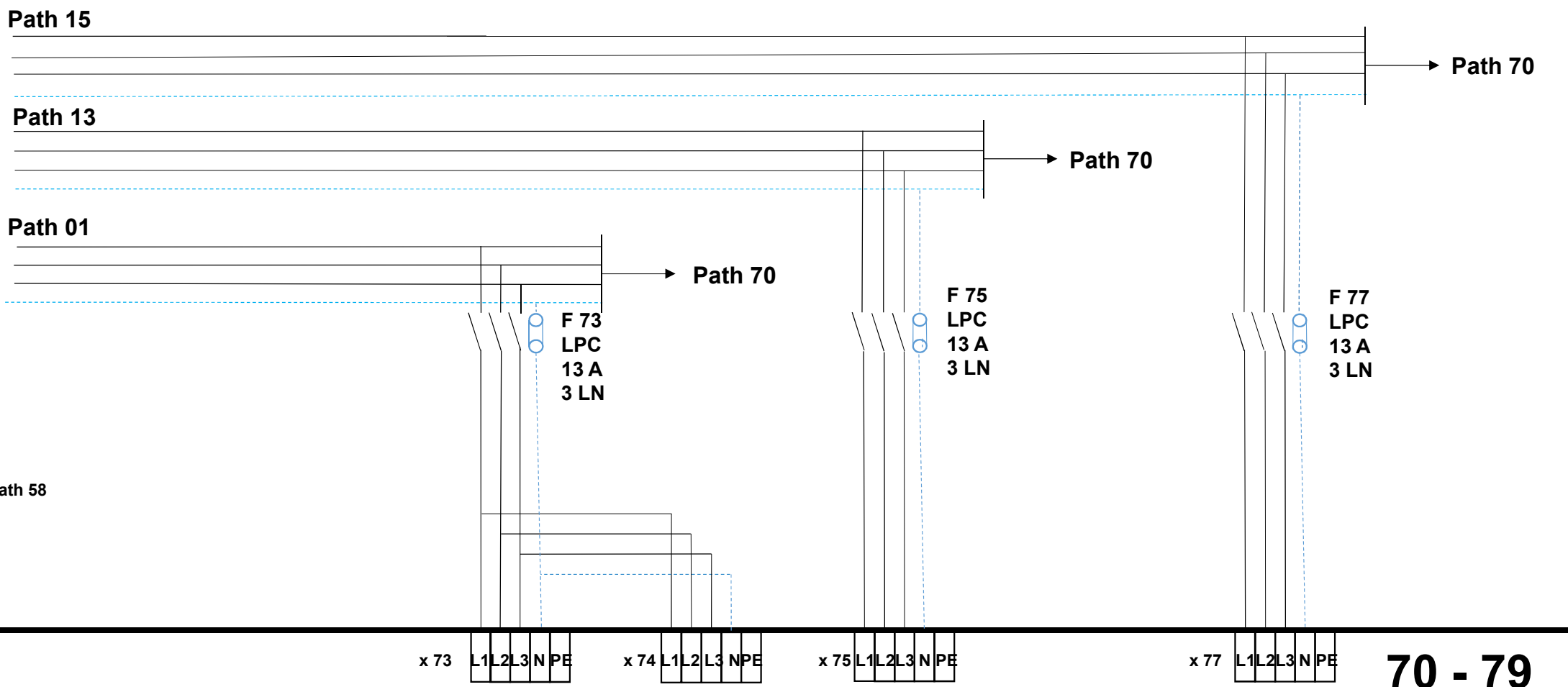

New Low tension distribution  
Comboni Hospital  
Sogakope

70 - 79



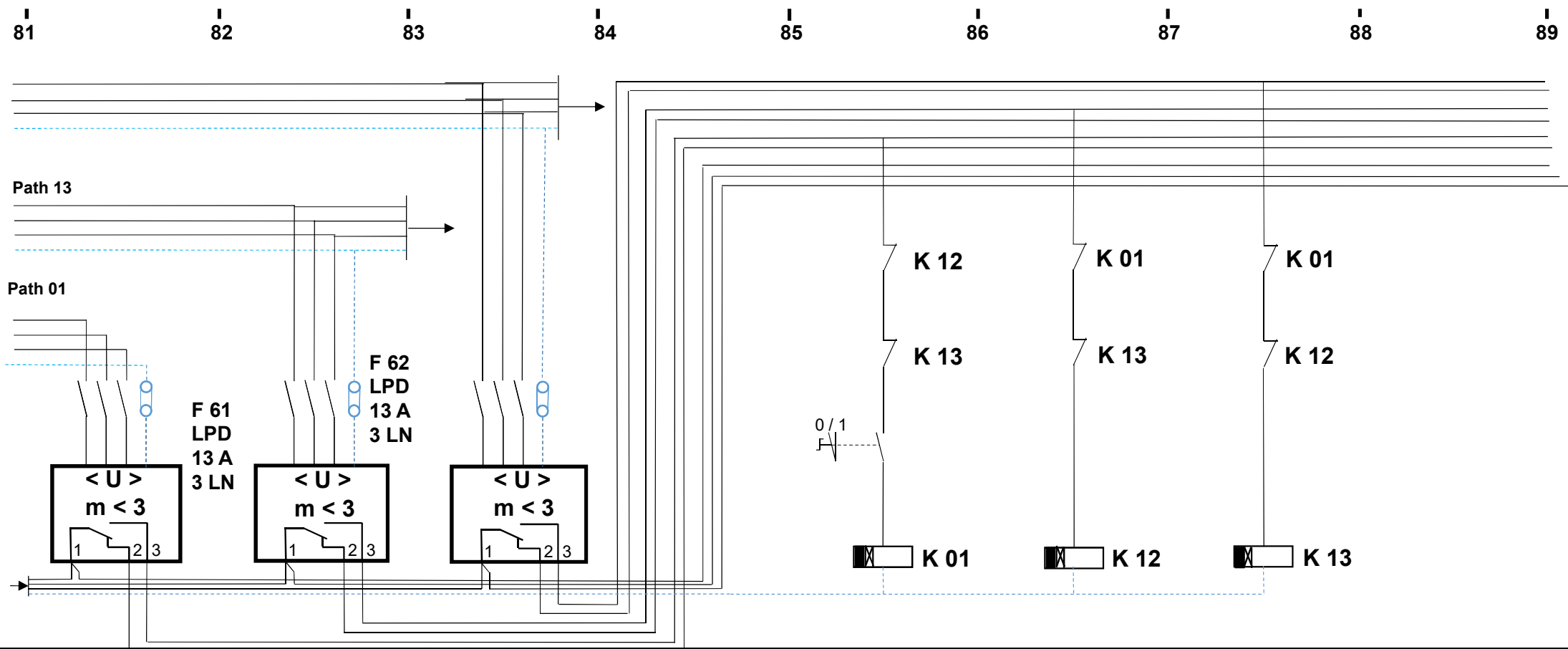

Tension and phase  
control relays  
VRA - ECG

Tension and phase  
control relays  
Genset 1

Tension and phase  
control relays  
Genset 2

New Low tension  
distribution  
Comboni Hospital  
Sogakope

80 - 89

91 92 93 94 95 96 97 98 99

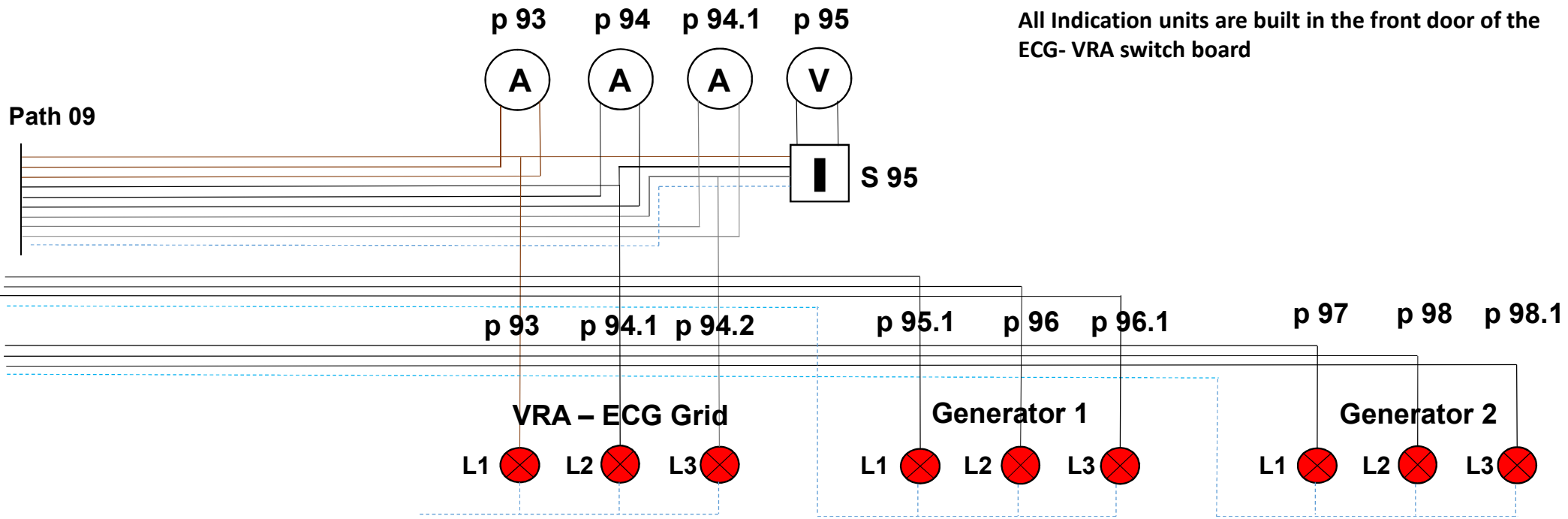

**New Low tension 90 - 99  
distribution  
Comboni Hospital  
Sogakope**

## Main Low Tension Distribution with Genset change over (available in Agogo)



**Part of low tension Distribution**



**Power factor compensation 100 kVar**

